



Pneumatic-Pneumatic Positioner

Lever type Rotary type

Series IP5000/IP5100

High performance positioner
Resistant to hostile environments,
Exceptional shock and vibration performance



IP5100/Rotary type

IP5000/Lever type

High performance positioner

Resistant to hostile environments, Exceptional shock and vib

Lever type

Rotary type

Series IP5000/IP5100

Resistant to vibration

Easy to attach small diaphragm actuators (IP5000 type)

Pneumatic piping ports gathered on the left-hand side of the positioner body eliminate interference with the actuator bottom (flange and duct). It exhibits extremely stable control characteristics even when a small actuator is mounted on it.



Standardization of fork lever joint (IP5100 type)

Linkage design tolerates a slight misalignment of shafts.

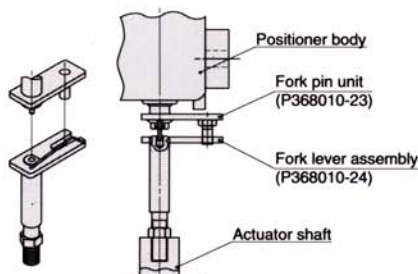

Approved by JIS F8007 IP55

A centralized exhaust system enhances both dust-proof and water-proof qualities. Epoxy-type coating inside the body prevents corrosion due to moisture.

Cross section of the exhaust system

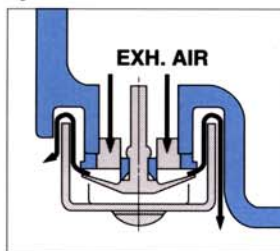

Employs the combination of the check valve and the labyrinth effect.

Compact and light weight

IP5000 is approx. 35% and IP5100 is approx. 45% lighter than existing IP300/310 types.

Energy saving

Air consumption is approx. 30% less than existing types.

Interchangeable

The side mounting hole is interchangeable with the existing series IP300/IP600 and IP6000.

Complete optional specifications

- Opening indicator (IP5100 type)
- Built-in bypass (SIG-OUT1) (IP5000 type)
- Built-in equalizing valve (OUT1-OUT2) (IP5100 type)

ration performance



IP5000

IP5100

Easy maintenance

Maintenance and parts replacement made easy by modular construction.

IP5000 / Lever type

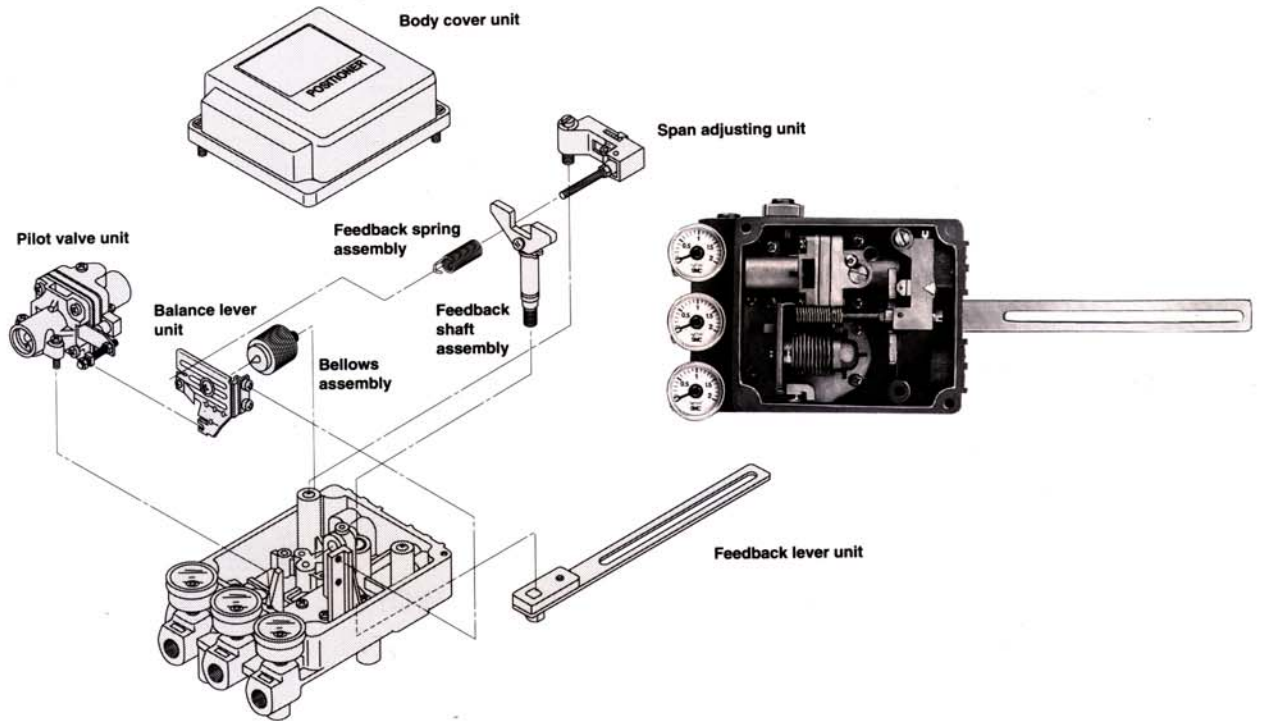

IP5100 / Rotary type

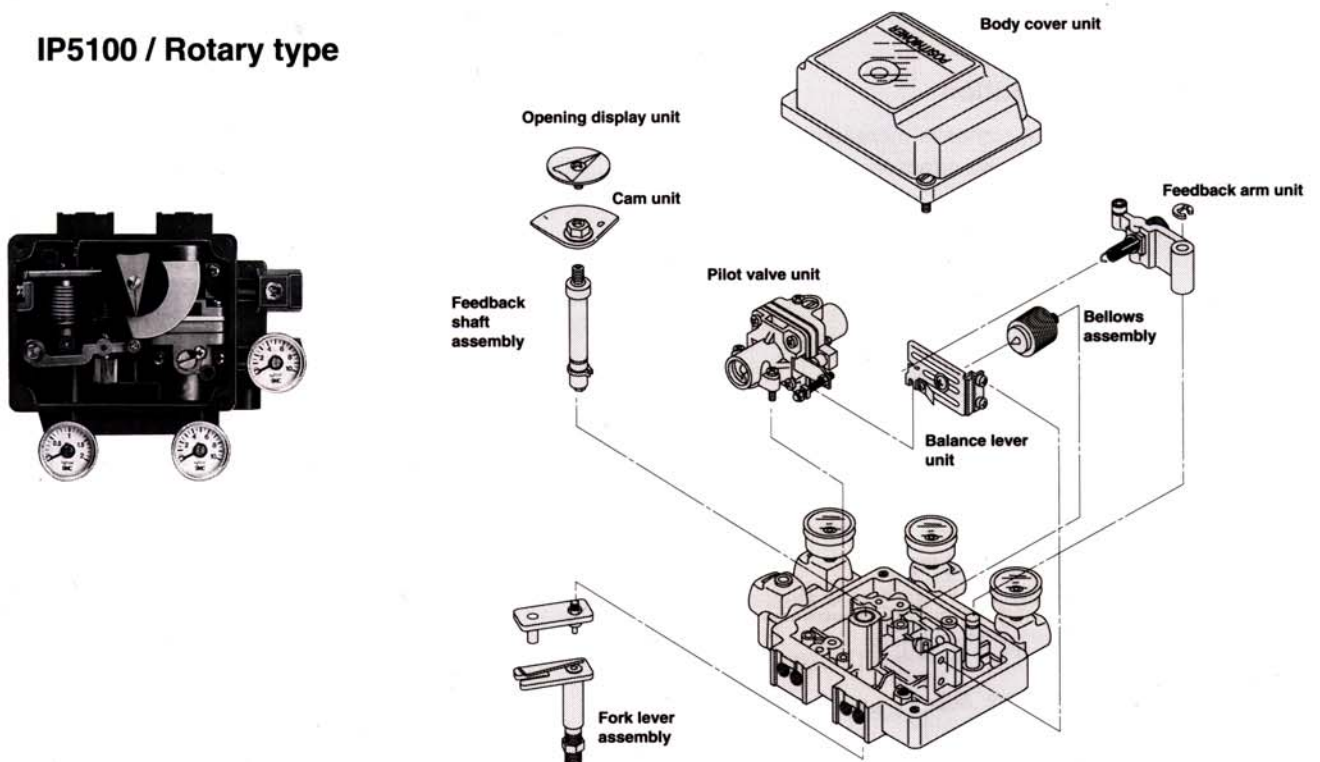

Piping method

IP5000 Lever type

Single action

Positive operation

When the input signal is increased, the stem extends.

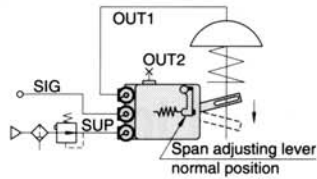

OUT2 is plugged

When the input signal is increased, the stem extends.
(Positive valve operation by its reverse operation mode)

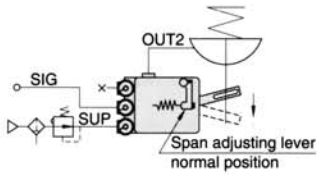

OUT1 is plugged

Reverse operation

When the input signal is increased, the stem retracts.
(Reverse valve operation by its positive operation mode)

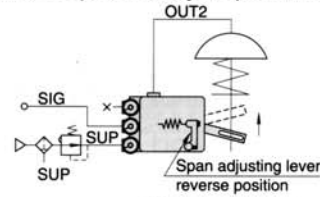

OUT1 is plugged

When the input signal is increased, the stem retracts.

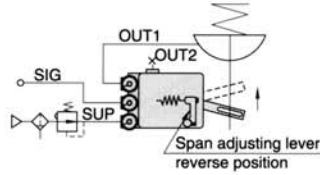

OUT2 is plugged

Double action

Positive operation

When the input signal is increased, the cylinder rod extends.

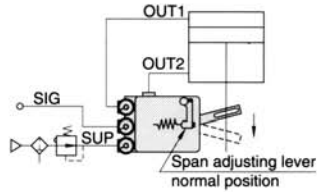

Reverse operation

When the input signal is increased, the cylinder rod retracts.

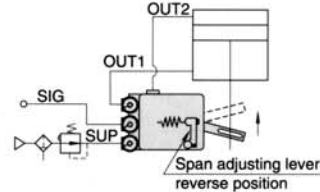

IP5100 Rotary type

Single action

Positive operation

When the input signal is increased, the actuator shaft rotates in a clockwise direction.

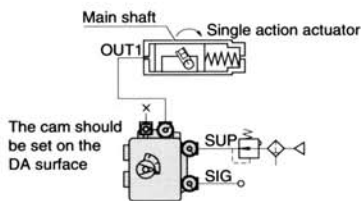

Reverse operation

When the input signal is increased, the actuator shaft rotates in a counter-clockwise direction.

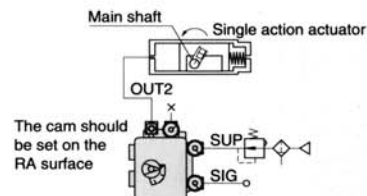

Double action

Positive operation

When the input signal is increased, the actuator shaft rotates in a clockwise direction.

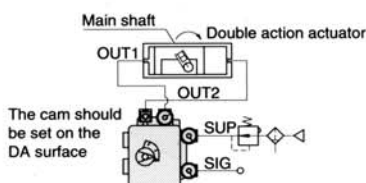

Reverse operation

When the input signal is increased, the actuator shaft rotates in a counter-clockwise direction.

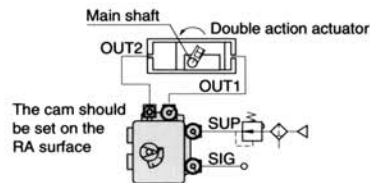

Pneumatic - Pneumatic Positioner

IP5000/IP5100



IP5000



With opening display



IP5100

Without opening display

Specifications

Item	Type	IP5000		IP5100	
		Lever type lever feedback		Rotary type cam feedback	
		Single action	Double action	Single action	Double action
Supply pressure		0.14 ~ 0.7MPa {1.4 ~ 7.1kgf/cm ² }			
Input pressure		0.02 ~ 0.1MPa {0.2 ~ 1kgf/cm ² }			
Stroke		10 ~ 85 mm		60° ~ 100°	
Sensitivity		Within 0.1%F.S.		Within 0.5%F.S.	
Linearity		Within ±1%F.S.		Within ±2%F.S.	
Hysteresis		Within 0.75%F.S.		Within 1%F.S.	
Repeatability		Within ±0.5%F.S.			
Air consumption		Note 1) 5 ℓ/min(ANR) or less(SUP=0.14MPa) 11 ℓ/min(ANR) or less(SUP=0.4MPa)			
Output flow		Note 1) 80 ℓ/min(ANR) or more(SUP=0.14MPa) 200 ℓ/min(ANR) or more(SUP=0.4MPa)			
Ambient and fluid temperature		-20°C ~ 80°C (Standard)			
Coefficient of temperature		Within 0.1%F.S. / °C			
Air port		Rc(PT)1/4 (Standard)			
Main component parts		Aluminum diecast, Stainless steel, Brass, Nitrile rubber			
Weight		Approx. 1.4kg		Approx. 1.2kg	
Dimensions		118x102x86 (Body)		118x92x77.5 (Body)	

Note 1) Standard air temperature : 20° (293K), Absolute pressure : 760 mmHg (101.3KPa), Relative humidity : 65%

How to Order

IP5 000 - 0 1 0 [] [] []

Type

000	Lever type lever feedback
100	Rotary type cam feedback

Input pressure classification

0	0.2-1.0kgf/cm ² (Standard)
1	1/2 split 0.2-0.6, 0.6-1.0kgf/cm ²

Pressure gauge (SUP, OUT1)

0	None
1	2kgf/cm ²
2	3kgf/cm ²
3	10kgf/cm ²

Opening display

0	None
1	With

Note 3) IP5000type - 0 only

Ambient temperature

Nil	-20~80°C (Standard)
T	-5~100°C (for high temp.)
L	-30~60°C (for low temp.)

Accessories

Accessories	Description	Notes
Nil	None (Standard)	IP5000 has standard lever for stroke (10-85mm)
A	φ 0.7 Output restriction with pilot valve	Accessory for IP5000, IP5100 small capacity actuator
B	φ 1.0 Output restriction with pilot valve	
C	Fork lever joint M	Accessory for IP5100
D	Fork lever joint S	
E	For stroke 35~100mm with lever unit	Note 2) Accessory for IP5000
F	For stroke 50~140mm with lever unit	

Note 1) If two or more accessories are required, the part numbers should be made according to alphabetical order. (ex. IP5000-010-AD)

Note 2) The standard lever is not attached to accessories E and F.

Pressure gauge, piping port

Nil	PT(Standard)
N	NPT
F	PF

Precautions

- 1 Avoid impact to positioner while transporting and handling.
- 2 Operate within specified temperature range to prevent deterioration of seals.
- 3 Attach a body cover to the positioner when it is in use or left in the field in order to avoid rain water.
- 4 Take measures to avoid dew condensation if the positioner is exposed to high temperature and humidity during transportation or storage or when it is left on the site.
- 5 The zero point is subject to the mounting position. Adjust the zero point after installation on the side.

Series IP5000/IP5100

Pilot valve with output restriction (IP5000, 5100 type)

Mounting on a small-size actuator may cause hunting. For prevention, a pilot valve with a built-in output restriction is available. The restriction is removable.

Fork lever joints (IP5100 type)

Fork-lever rotary joints are available that tolerate small misalignments between positioner and actuator shaft. These are available in two standard sizes. When the side of the positioner is used for mounting, the fork lever assembly Type M is interchangeable with the existing serration couplings.

Fork lever joint

Part name	Part number
Fork lever assembly M	P368010-24
Fork lever assembly S	P368010-25

Side mounting with the fork lever assembly M

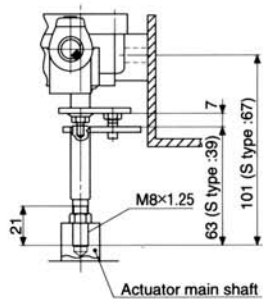

Rear mounting with the fork lever assembly S

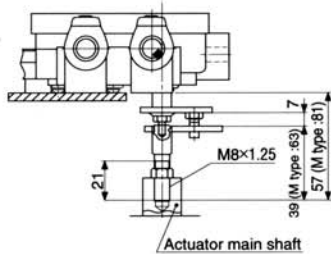

External feedback lever (IP5000 type)

The feedback lever is selected according to valve stroke. Consult factory for strokes less than 10mm.

External feedback lever

Stroke	Order code	Unit number	Dimension M	Dimension N
10~85mm	(Nil)	P378010-11	125	150
35~100mm	(E)	P378010-12	110	195
50~140mm	(F)	P378010-13	110	275

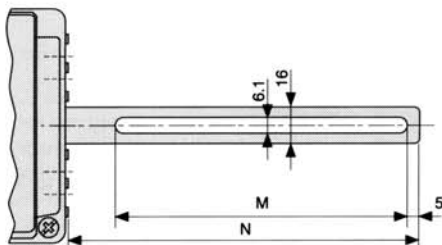

Installation

IP5000 type (Lever type lever feedback)

The unit should be mounted using bolts firmly fixed through mounting holes on the side or back of the positioner.

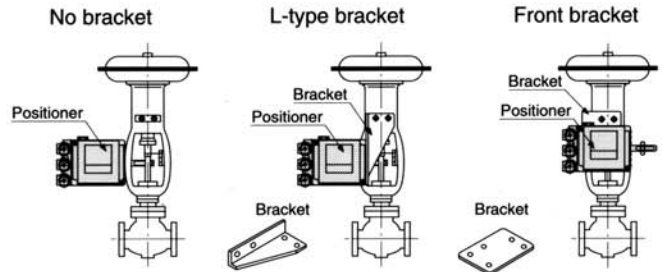

When the positioner side is used for mounting, the "P" mark mounting thread is interchangeable with the existing IP300 type, while the "E" mark mounting thread is interchangeable with the existing IP600 and IP6000 types.

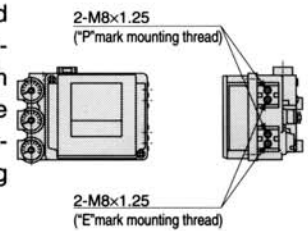

Locational relationship between positioner and connecting fittings

A connecting fitting or pin to transfer the displacement of valve stem should be mounted at a position so that the feedback lever is at right angles to the valve stem for an input pressure of 50%. The following figure is the configuration viewed from the front.

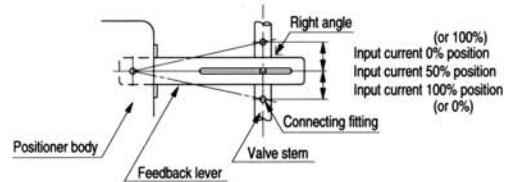

The feedback deflection angle should be 10°~30° during operation.

IP5100 type (Rotary type cam feedback)

Make a bracket to mount the positioner and rotary actuator according to their mounting method, and mount them by using mounting thread on the side or at the back of the positioner so that the feedback shaft of the positioner and the main shaft of the rotary actuator becomes nearly aligned.

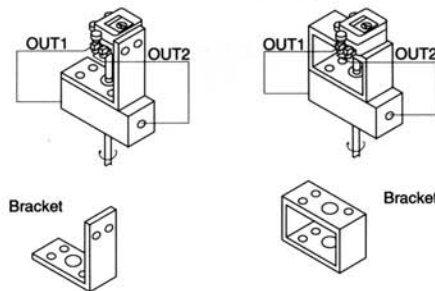

Installation using the thread on the side of positioner

Installation using the back of the positioner

When the positioner side is used for mounting, the "P" mark mounting thread is interchangeable with the existing IP310 type, while the "E" mark mounting thread is interchangeable with the existing IP610 and IP6100 types. The fork lever assembly type M, interchangeable with the existing serration couplings, can be used as it is.

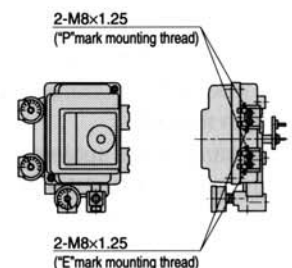

Principle of Operation

IP5000 type

When the input pressure applied to the SIG port of the positioner increases, bellows 1 press balance lever 2 to the right and left. As this movement moves flapper 3 to the right and left through connecting spring 4, the gap between nozzle 5 and flapper 3 widens, and the nozzle back pressure of pilot valve 6 drops. As a result, the pressure balance in the constant pressure chamber is broken, and exhaust valve 7 presses inlet valve B 8 to the right, thus opening inlet port B. Then, output pressure OUT1 rises, and driven diaphragm 9 moves downward.

The movement of driven diaphragm 9 deflects feedback arm 10 to the right through feedback lever 11, transmission lever 12, and roller 13. Such deflection increases the tension of feedback spring 14 and acts on balance lever 2.

Since driven diaphragm 9 moves until the tensile force of feedback spring 14 and the force generated by bellows 1 balance, it is always set in the position proportional to the input pressure. When the signal air pressure decreases, the operation is reversed.

IP5000 type Block diagram of operating principle

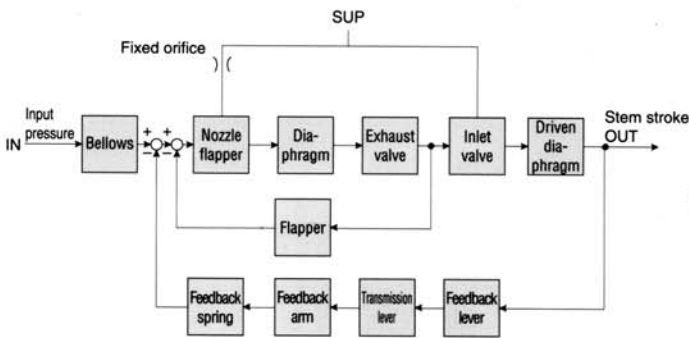

IP5000 Principle of operation

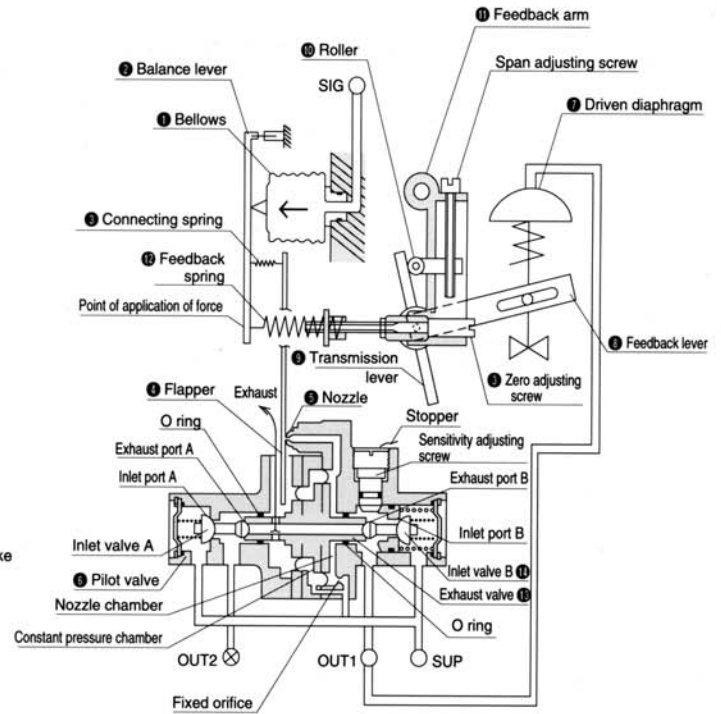

IP5100 type

When the input pressure applied to the SIG port of the positioner increases, bellows 1 press balance lever 2 to the right and left. As this movement moves flapper 3 to the right and left through connecting spring 4, the gap between nozzle 5 and flapper 3 widens, and the nozzle back pressure of pilot valve 6 drops. As a result, the pressure balance in the constant pressure chamber is broken, and exhaust valve 7 presses inlet valve B 8 to the right, and output pressure OUT1 increases.

In the meantime, the movement of exhaust valve 7 to the right and left opens exhaust port A, and output pressure OUT2 decreases. Therefore, pressure difference is generated between pressure chamber 1 and pressure chamber 2 of oscillating actuator 9, and actuator shaft 10 turns in the direction of the arrow. The movement of actuator shaft 10 deflects feedback arm 11 to the right through feedback shaft 12, cam 13, and bearing 14. Such deflection increases the tension of feedback spring 15 and acts on balance lever 2.

Since oscillating actuator 9 moves until the tensile force of feedback spring 15 and the force generated by bellows 1 balance, it is always set in the position proportional to the input pressure. When the signal air pressure decreases, the operation is reversed.

IP5100 type Block diagram of operating principle

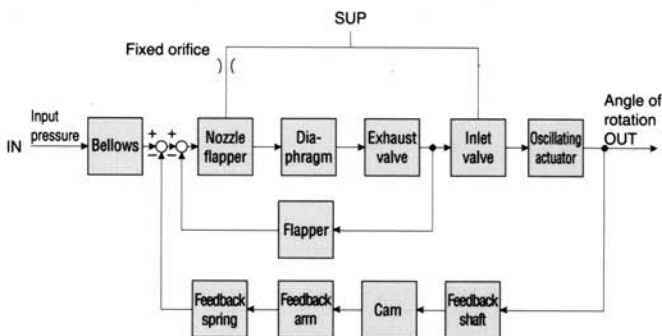

IP5100 Principle of operation

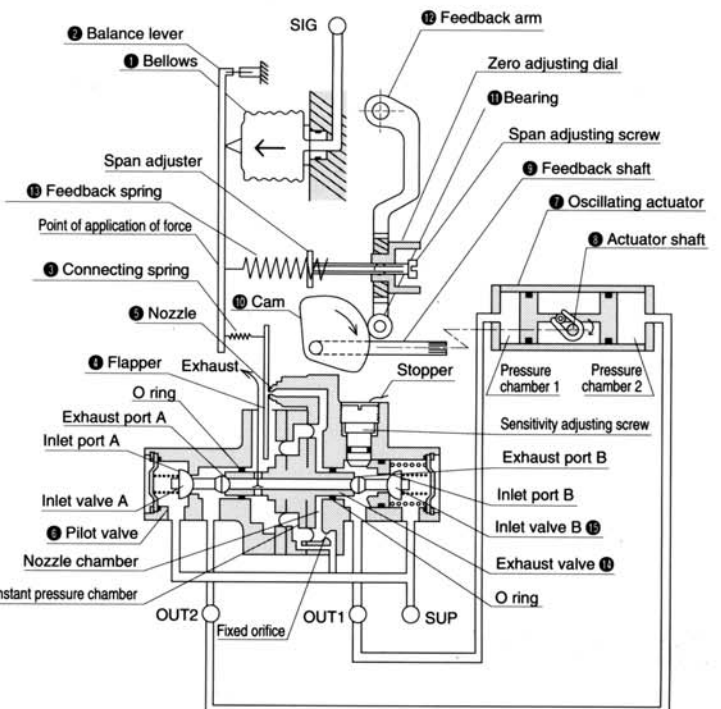

Series IP5000/IP5100

IP5000 type (Lever type lever feedback)

(mm)

Scale : 1/5

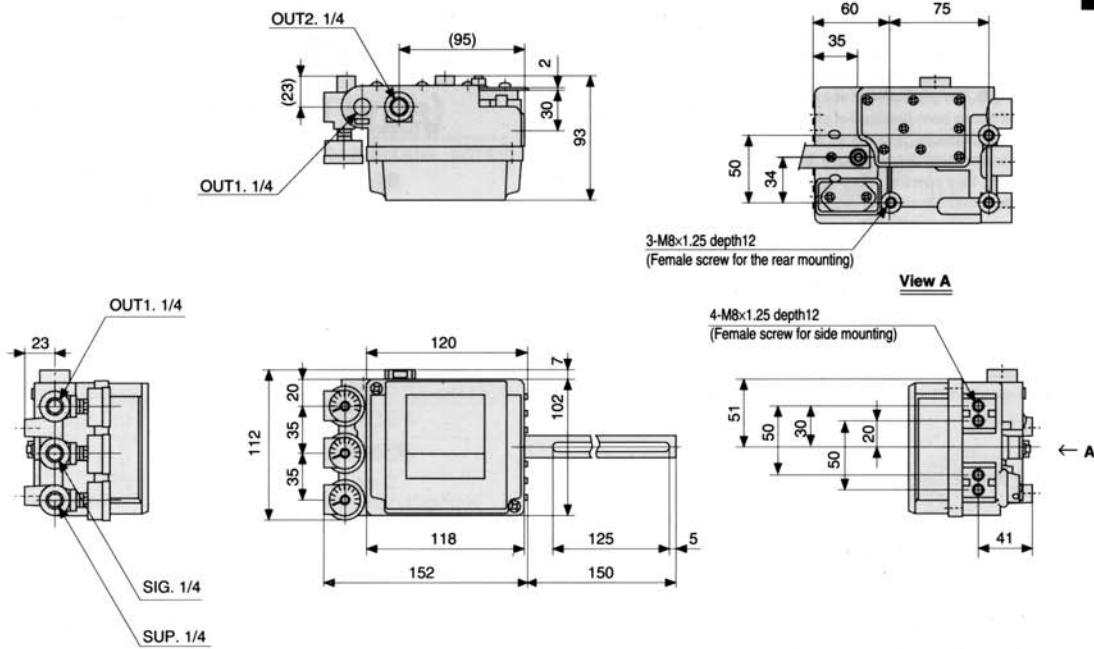

IP5100 type (Rotary type cam feedback)

Scale : 1/5

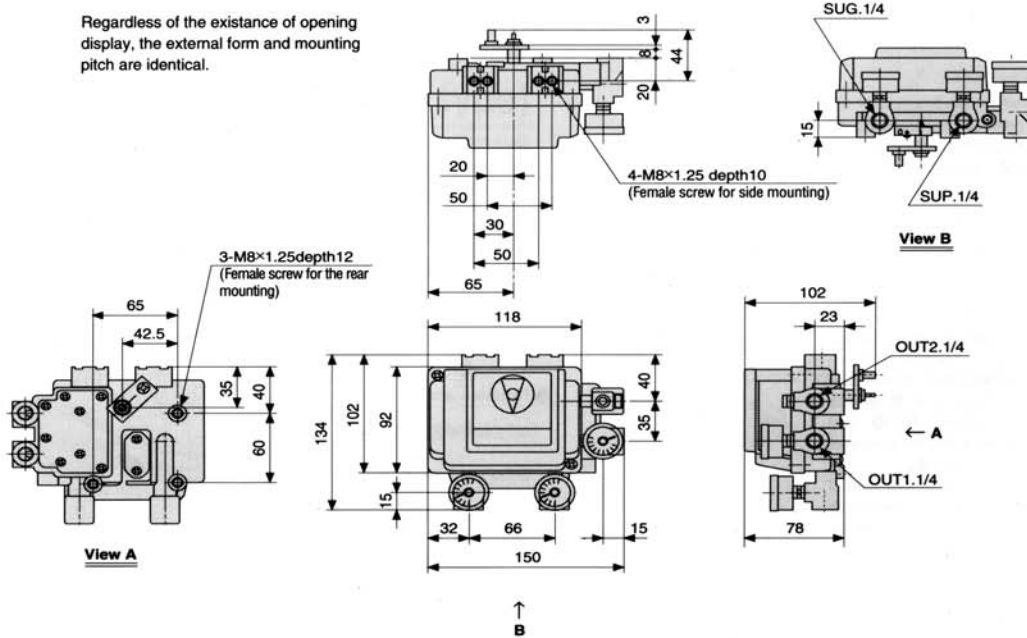

SMC CORPORATION

1-16-4, SHIMBASHI, MINATO-KU, TOKYO 105, JAPAN.
Tel:03-3502-2740 Fax:03-5251-7240

